

## Flexicon FPA Fitting Instructions FM0100-1

Instructions for assembling/removing fitting to/from conduit to ensure IP66 is maintained.  
Refer to Flexicon catalogue for all available fitting types and sizes.

Safety Note: When handling cutters, knives, saws, pointed tools etc, suitable eye and hand protection should always be worn.

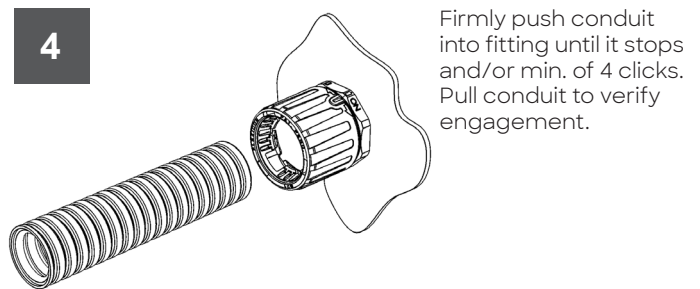
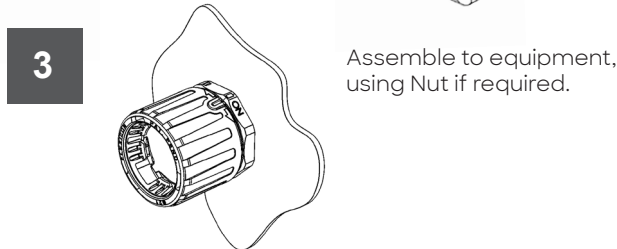
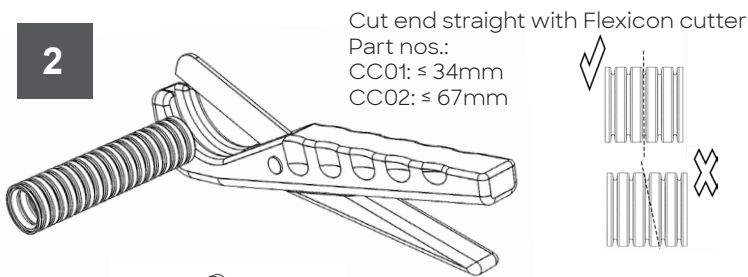
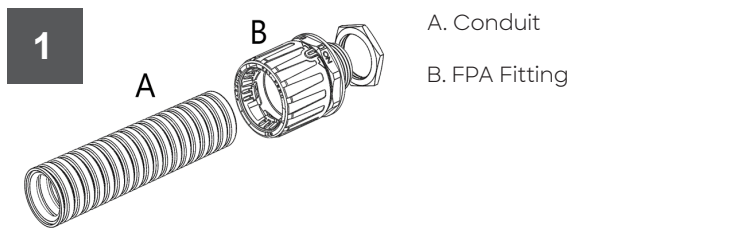

### To remove conduit:

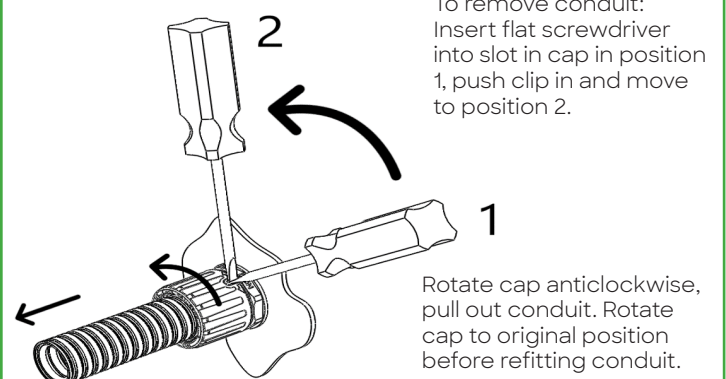

### Torque Values for Retaining Nut

Tightening torque for METAL thread fittings and supplied fibre washer or optional O ring (Nickel plated brass or stainless steel locknuts are available separately—see table below for ordering code).

Thread Size	Locknut (Nm)		Threaded Entry (Nm)		Optional Locknut	
	Min	Max	Min	Max	Plated Brass	St. Steel
M16	17	27	22	36	B-M16	SS-M16
M20	22	32	28	45	B-M20	SS-M20
M25	22	32	33	54	B-M25	SS-M25
M32	28	36	39	54	B-M32	SS-M32
M40	55	72	55	72	B-M40	SS-M40
M50	66	81	66	81	B-M50	SS-M50

Tightening torque for PLASTIC thread fittings with supplied plastic locknut and plastic washer (Steel or nickel plated brass locknuts can be used available separately—use these torque values).

Thread Size	Locknut (Nm)		Threaded Entry (Nm)	
	Min	Max	Min	Max
M16	2	3	3	5
M20	3	4	4	7
M25	4	6	8	14
M32	6	9	11	23
M40	9	14	17	23
M50	9	14	17	23

